

KWM-380 TRANSCEIVER (622-5093-001, -101)
HF-380 TRANSCEIVER (622-3580-001, -101)

SERVICE BULLETIN NO 6

CORRECT TRANSMIT HUM

This service bulletin applies as follows:

EQUIPMENT	APPLIES TO SERIAL NUMBERS	PRODUCTION CUT-IN SERIAL NUMBERS
KWM-380 622-5093-001	268 and below, 270 through 481, 483, 484, 486, 488, 489, 491, 492, 494, 495, 497, 498, 500, 501, 502, 504, 505, 508, 509, 511, 513, 516, 520, 523, 525, 527, and 530 through 537	269, 482, 485, 487, 490, 493, 496, 499, 503, 506, 507, 510, 512, 514, 515, 517, 518, 519, 521, 522, 524, 526, 528, 529, 538 and above
622-5093-101	All	None
HF-380		
622-3580-001	35 and below, 37 through 43, 45, 46, 49, and 50	36, 44, 47, 48, 51 and above
622-3580-101	All	None

The purpose of this service bulletin is to correct a transmit hum caused by a ground loop between the front panel and the receiver/exciter card ground plane.

This modification replaces the mic jack (J2) with a jack that has an insulated sleeve contact to break the ground loop.

Estimated time required is 1.0 man-hour.

Rockwell- Collins | SERVICE BULLETIN

Collins Telecommunications Products Division/Rockwell International

The modification parts are listed in the material information paragraph. For information concerning parts, contact Collins Service Center, Rockwell International, 6001 Threadgill Avenue, El Paso, Texas 79924. Reference KWM-380/HF-380 Service Bulletin No 6 in all correspondence.

No special tools or equipment are required.

MODIFICATION PROCEDURE

- A. Turn off all power to the transceiver.
- B. Remove the dust cover by removing the four screws located adjacent to the four feet on the bottom of the transceiver.

CAUTION: EXTREME CARE MUST BE EXERCISED WHEN REMOVING THE EXISTING MIC JACK TO AVOID SCRATCHING THE FRONT PANEL OVERLAY. PROTECT THE SURROUNDING AREA WITH MASKING TAPE.

- C. Unsolder and remove the wires connected to mic jack J2 (figure 1).
- D. Remove and discard J2 by removing the nut that secures the jack to the front panel. Discard the bypass capacitors mounted on the jack.
- E. Install a new jack (647-2739-001) with the orientation shown in figure 2 using a black nut (334-1657-020).

NOTE: Refer to figure 2 while performing steps F through J.

- F. Install 0.01 uF capacitor C1 (913-3331-020) between J2 tip and sleeve.
- G. Install 0.001 uF capacitor C2 (913-3331-010) between J2 ring and sleeve.
- H. Install 0.01 uF capacitor C3 (913-3331-020) between J2 sleeve and J1 sleeve (front panel ground).
- I. Reconnect the blue wire (removed in step C) to J2 tip.
- J. Reconnect the shielded cable white wire to J2 ring and black wire to J2 sleeve.

NOTE: Refer to figure 3 for an interconnect diagram which includes the above changes.

- K. Reinstall the transceiver dust cover.
- L. Mark SB 6 on the transceiver service bulletin information chart. If the unit does not have an information chart, attach a chart (280-3778-010) near the nameplate.

Rockwell- Collins | SERVICE BULLETIN

Collins Telecommunications Products Division/Rockwell International

MATERIAL INFORMATION

The parts listed below are required to modify one KWM-380 or one HF-380.

<u>COLLINS PART NUMBER</u>	<u>QTY</u>	<u>UNIT PRICE</u>	<u>DESCRIPTION</u>
647-2739-001	1		Jack, J2
334-1657-020	1		Nut
913-3331-020	2		Capacitor, 0.01 uF, C1, C3
913-3331-010	1		Capacitor, 0.001 uF, C2
*280-3778-010	1		Chart, information

*Order if needed.

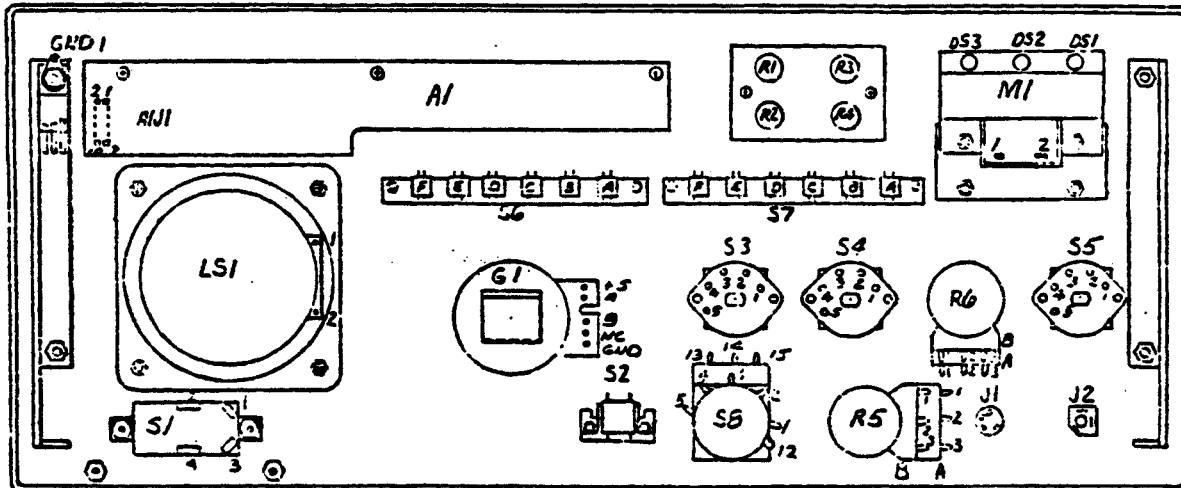

KWM-380/HF-380 Front Panel, Rear View
Figure 1

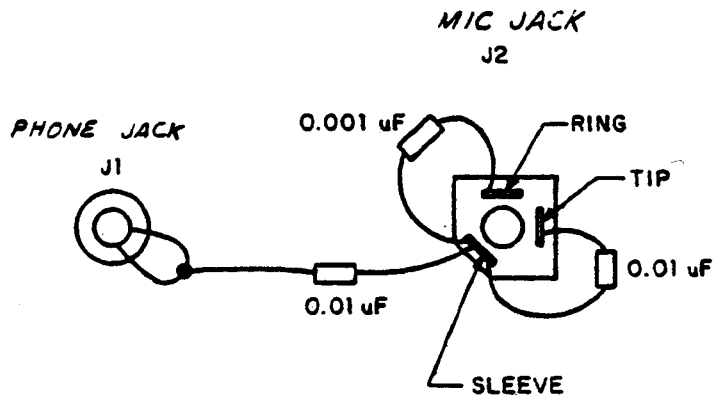

Mic Jack J2, Orientation Diagram
Rear View of Front Panel
Figure 2

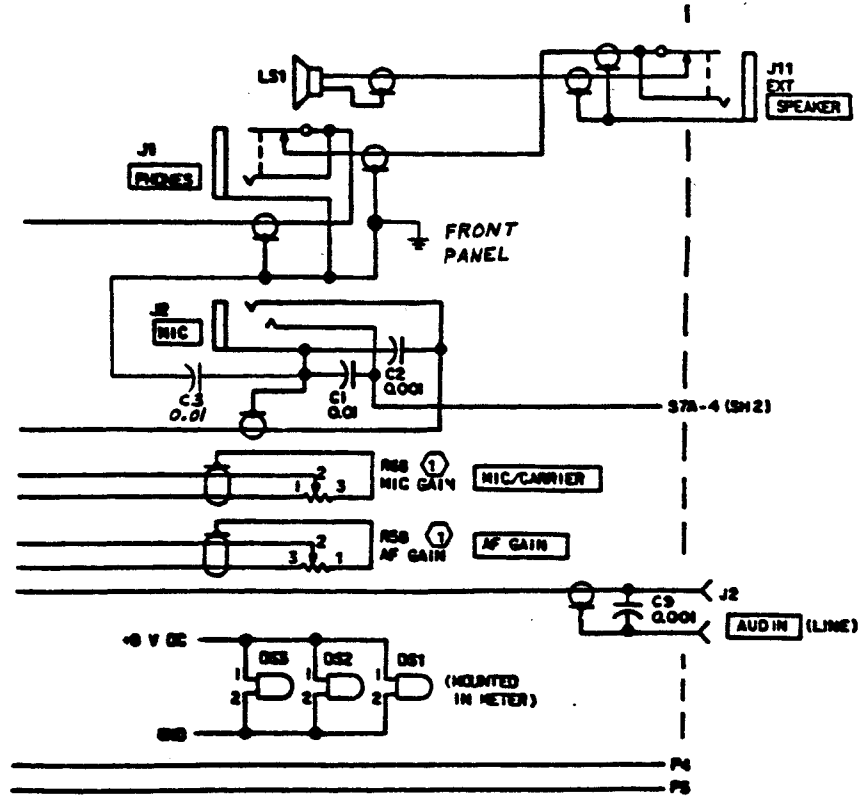

634-6823
T96-2232-005

P/O KWM-380/HF-380 Interconnect Diagram
Figure 3